

Mid-rise scissor/low portable lift

User Manual

Attention:

Congratulations on your purchase of this Hydraulic Scissor Lift. This model is the result of our vast experience in the production of fine lifting vehicles machines. It represents the high degree of craftsmanship and reliability that have made us a leader in these fields.

It is a wheels free hydraulic lift bridge with a lower profile, designed and built to meet the requirement of the operator changing tires in the tire shop and for minor mechanical jobs (oil change, changing brake pads etc.) as it reaches a lifting height of around one meter.

This manual will give you an understanding of the operation, inspection, and basic maintenance of this lift. If you have any questions concerning the operation or maintenance of your lift, please consult the dealer.

The design and manufacture of this lift fully comply with the lifting standards of CE. We have met these standards without reducing the performance or economy of operation of the lift. To maintain these high standards, it is important that you and your dealer pay close attention to the recommended maintenance schedules and operating instructions contained within this manual.

NOTES:

In the normal use of the machine, ensure the upper part of the cylinder does not rust, wear out the sealing ring, the user should be rise lift to the limit switch in every week, repeated several times to lubricate the upper part of the cylinder.

Special specification

1. Equipment damage which in the process of shipment shall be claim by the
2. buyer to the carrier.
3. Design and manufacture have considered the safety performance. However, proper training and thorough operation can increase the safety. Not reading illustrates, shall not operate or repair the equipment.
4. Identify the motor and the current state requirement of the nameplate, by professional and qualified electrician to connect.
5. Products of the company to the part structure improvement without notice. On the previous sales product updates without any obligation to notify customer.
6. Not be more than the rated lifting weight.
7. Please carefully read the warning marks.

TABLE OF CONTENTS

1、	IMPORTANT MANUAL INFORMATION
2、	SAFETY INFORMATION
3、	TRANSPORT & UNPACKING
4、	SPECIFICATIONS
5、	WORKING PLACE
6、	INSTALLATION
7、	OPERATION
8、	STORING
9、	ELECTRIC SYSTEM
10、	HYDRAULIC SYSTEM
11、	STRUCTURE PRINCIPLE DIAGRAM

1、 IMPORTANT MANUAL INFORMATION

Particularly important information is distinguished in this manual by the following notations:



The Safety Alert Symbol means ATTENTION !
BECOME ALERT! YOUR SAFETY IS INVOLVED!



Failure to follow WARNING instructions could result in severe injury or death to the lift operator, a bystander or a person inspecting or repairing the lift.

CAUTION

A CAUTION indicates special precautions that must be taken to avoid damage to the lift.

NOTE

A NOTE provides key information to make procedures easier or clearer, and also some important things.

NOTE:

- 1.1 This manual should be considered a permanent part of this lift and should remain with it even if the lift is subsequently sold.
 - 1.2 We continually seek advancements in product design and quality. Therefore, while this manual contains the most current product information available at the time of printing, there may be minor discrepancies between your lift and this manual. If you have any questions concerning this manual, please consult your dealer.
-

2、SAFETY INFORMATION



THIS SCISSOR LIFT IS ONE KIND OF THE LIFTING EQUIPMENTS. ITS SAFE USE AND OPERATION ARE DEPENDENT UPON THE USE OF PROPER OPERATION TECHNIQUES AS WELL AS THE EXPERTISE OF THE OPERATOR. EVERY OPERATOR SHOULD KNOW THE FOLLOWING REQUIREMENTS BEFORE OPERATION THIS LIFT.

HE OR SHE SHOULD:

- OBTAIN THOROUGH INSTRUCTIONS FROM A COMPETENT SOURCE ON ALL ASPECTS OF LIFT OPERATION.
- OBSERVE THE WARNINGS AND MAINTENANCE REQUIREMENTS IN THE OWNER'S MANUAL.
- OBTAIN QUALIFIED TRAINING IN SAFE AND PROPER OPERATION TECHNIQUES.
- OBTAIN PROFESSIONAL TECHNICAL SERVICE AS INDICATED BY THE OWNER'S MANUAL AND/OR WHEN MADE NECESSARY BY MECHANICAL CONDITIONS.



Please read the following important labels carefully before operating this lift.

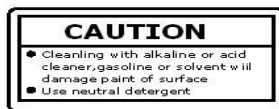
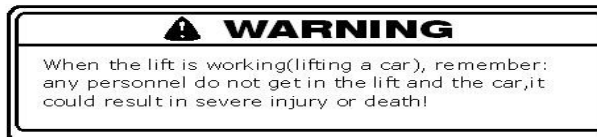
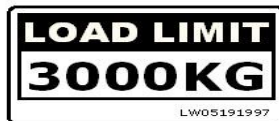

3、 TRANSPORT & UNPACKING

Depending on the standard request, this lift and the hydraulic pump are protected by two cartons with pallets. And the machine must be handled with a forklift with the forks positioned as shown in the figure.

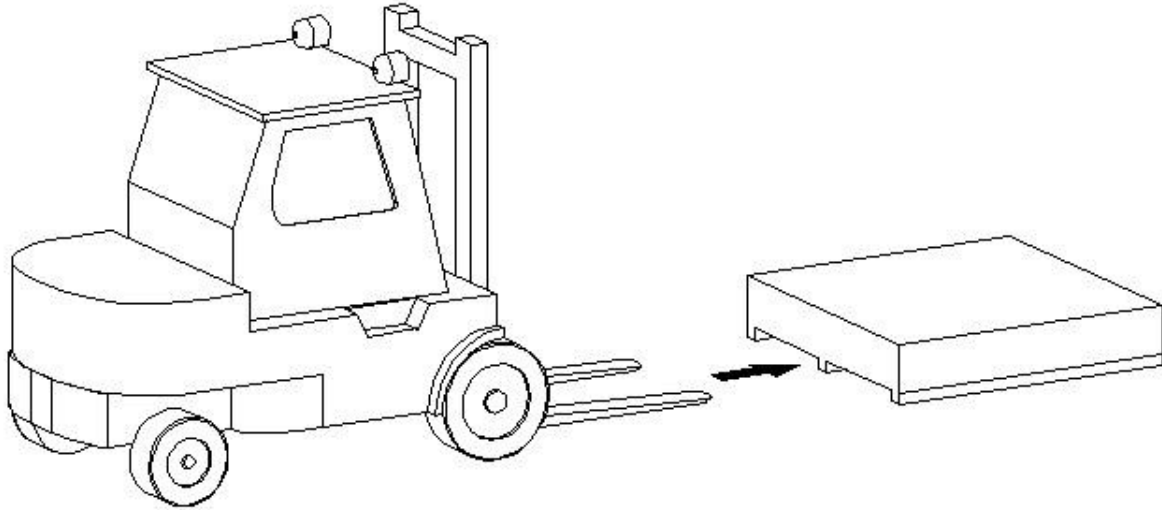

CAUTION 3.1 Once the packing material has been removed, check the machine for any signs of damage.

WARNING 3.2 Keep the packing materials out of the reach of children as they can be a source of danger.

Keep the packing for possible future transport.

4、 SPECIFICATIONS

Motor	110 VAC at 60 Hz, 1 Ph, 2.95 hp (2.2 kW)
Lifting Capacity	6614 lbs (3000 kg)
Max Lifting Height	39 3/8 in (1000 mm)
Lowered Height	4 9/64 in (105 mm)
Lifting Time	30 seconds
Air Supply	87 - 116 psi (6 - 8 bar)
Single Platform Length	55 1/8 in (1400 mm)
Single Platform Width	20 55/64 in (530 mm)
Width between Platforms	33 5/64 in (840 mm)
Overall Length (includes Ramps)	79 9/64 in (2010 mm)

Overall Width	74 51/64 in (1900 mm)
Product Weight	1142 lbs (518 kg)

5、WORKING PLACE

5.1 Choose the place the machine is to be installed in compliance with current work place safety regulations. The floor should not be broken or uneven so that the machine will be stable and the platform can move freely.

5.2 If the installation is out door, it must be protected by some kind of roofing against rain.

5.3 The following work environment conditions are applicable

① **Relative humidity: from 30-95% without condensation.**

② **Temperature: 5-55°C.**



The machine must not be operated in explosive atmospheres.

Maximum machine space requirements are 3200X2000mm with a minimum distance from walls as shown in the diagram.

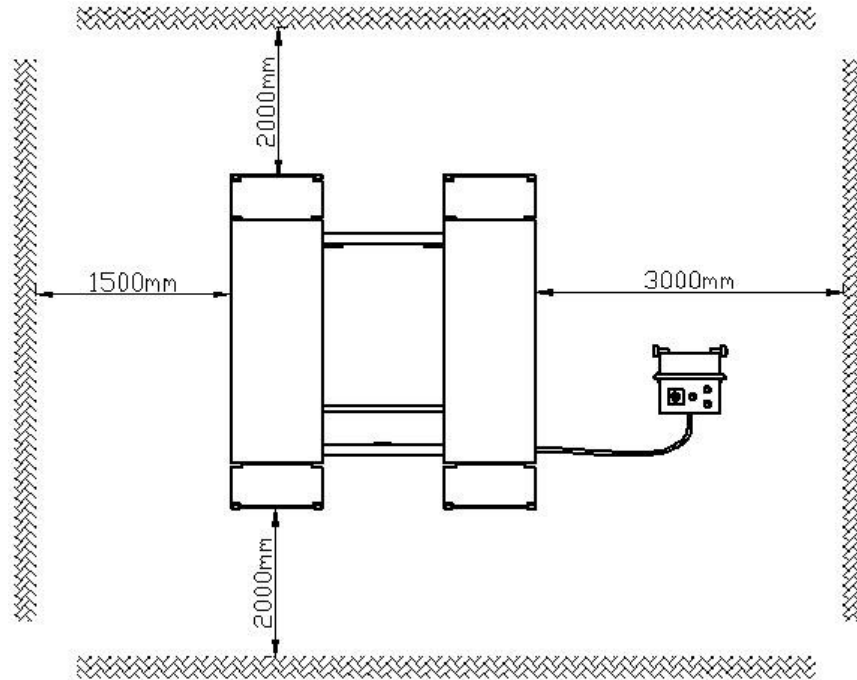

These measurements are also the machine working range. Persons other than specially trained and authorized operators are expressly forbidden to enter this area,

DESCRIPTION

Lift

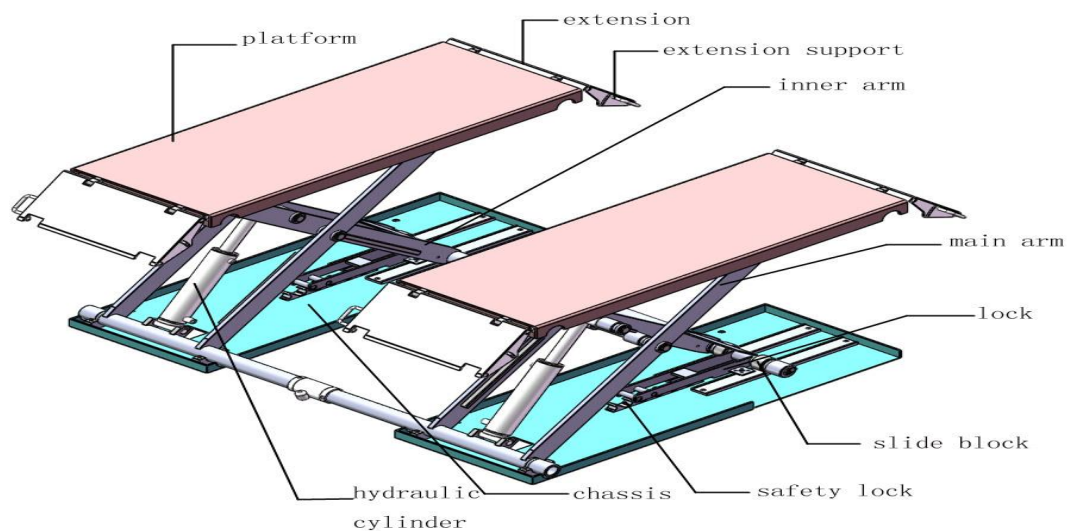

NOTE

It is main parts figure above. More detailed components and assembly please see exploded view

**NOTE**

It is main parts figure above. More detailed components and assembly please see exploded view

6、 INSTALLATION

6.1 Connecting pipes

There are two pipes from the hydraulic pump as shown in the figure. (X) is a pneumatic pipe and used for the safety lock. (Y) is a hydraulic oil pipe and used for the hydraulic cylinders.

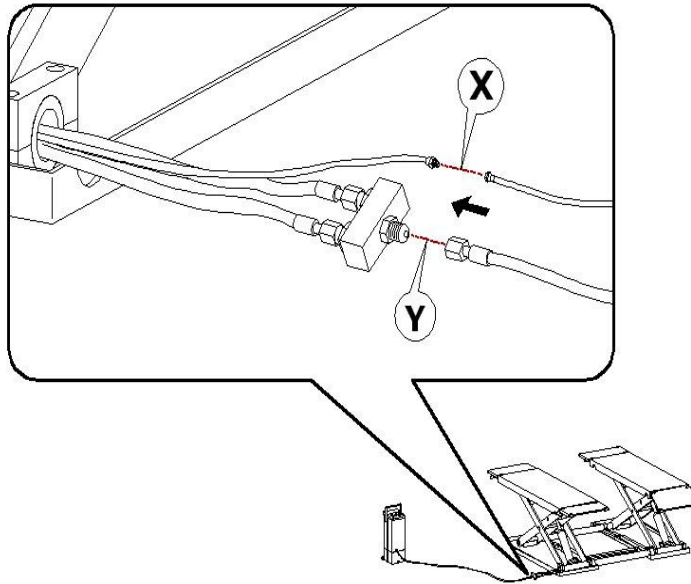

6.2 Enter hydraulic oil

Remove the motor box off, and then turn the oil cap anti-clockwise to open the oil inlet. Fill in the hydraulic oil 30# from the oil inlet as shown in the figure.

CAUTION

Use only given and eligible hydraulic oil, any other oil will cause severe damage to internal parts, such as the gear-pump, pipes and cylinders.

Oil inlet

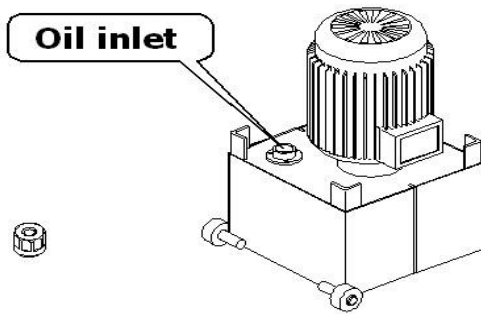

NOT

- Do not overfill the oil tank, otherwise it may overflow when the oil warms up and expands.
- Make sure that the oil tank cap is properly closed before working.

7、 OPERATION

During all operations, keep hands and other parts of the body as far as possible from moving parts of the machine. Necklace, bracelets and too large clothes, can be dangerous for the operator.



When the power supplied, turn the *POWER SWITCH* clockwise while the machine is on standby and an *INDICATOR* will show.

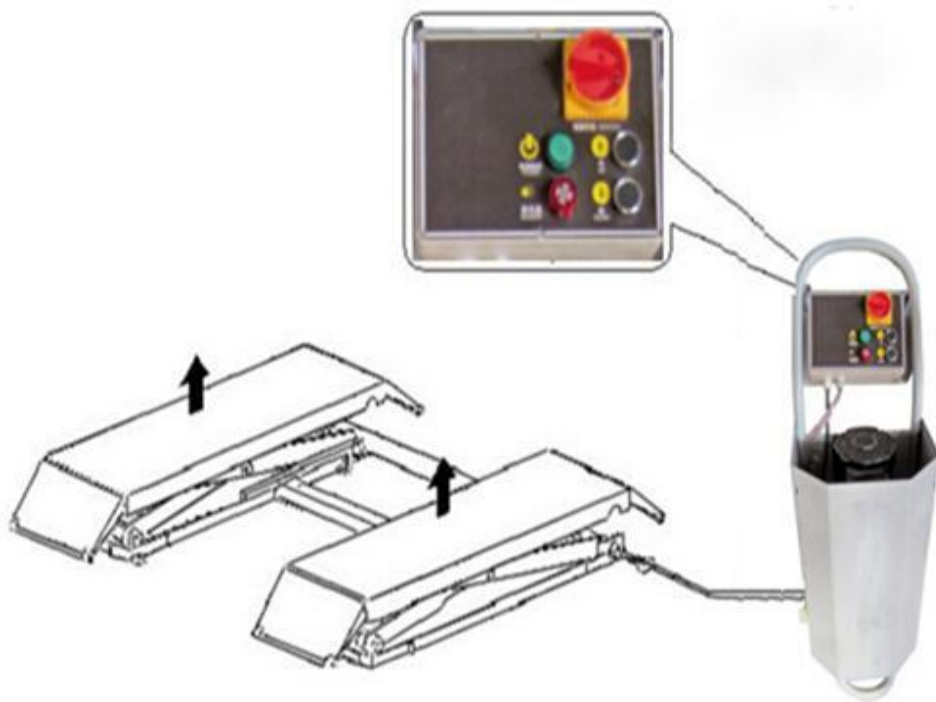

WARNING

When the lift is working (lifting a car), remember:
Any personnel do not get in the lift and the car, it could result in severe injury or death!

OPERATION

WARNING

During all operations, keep hands and other parts of the body as far as possible from moving parts of the machine. Necklace, bracelets and too large clothes, can be dangerous for the operator.



When the lift is working (lifting a car), remember:
Any personnel do not get in the lift and the car, it could result in severe injury or death!

8、STORING

If the machine as to be stored for a long time you have to :

8.1 Go down the platforms and no heavy object on them.

8.2 Disconnect the machine from all power sources.

8.3 Grease all the parts that could be damaged if they dry out.

8.4 Empty hydraulic oil reservoir and wrap the machine in a sheet of protective plastic to prevent dust from reaching the internal working parts.

If the machine as to working again after a long storing period, it is necessary to:

8.5 Put the oil into the reservoir again.

8.6 Restore the electric connection.

9、ELECTRIC SYSTEM

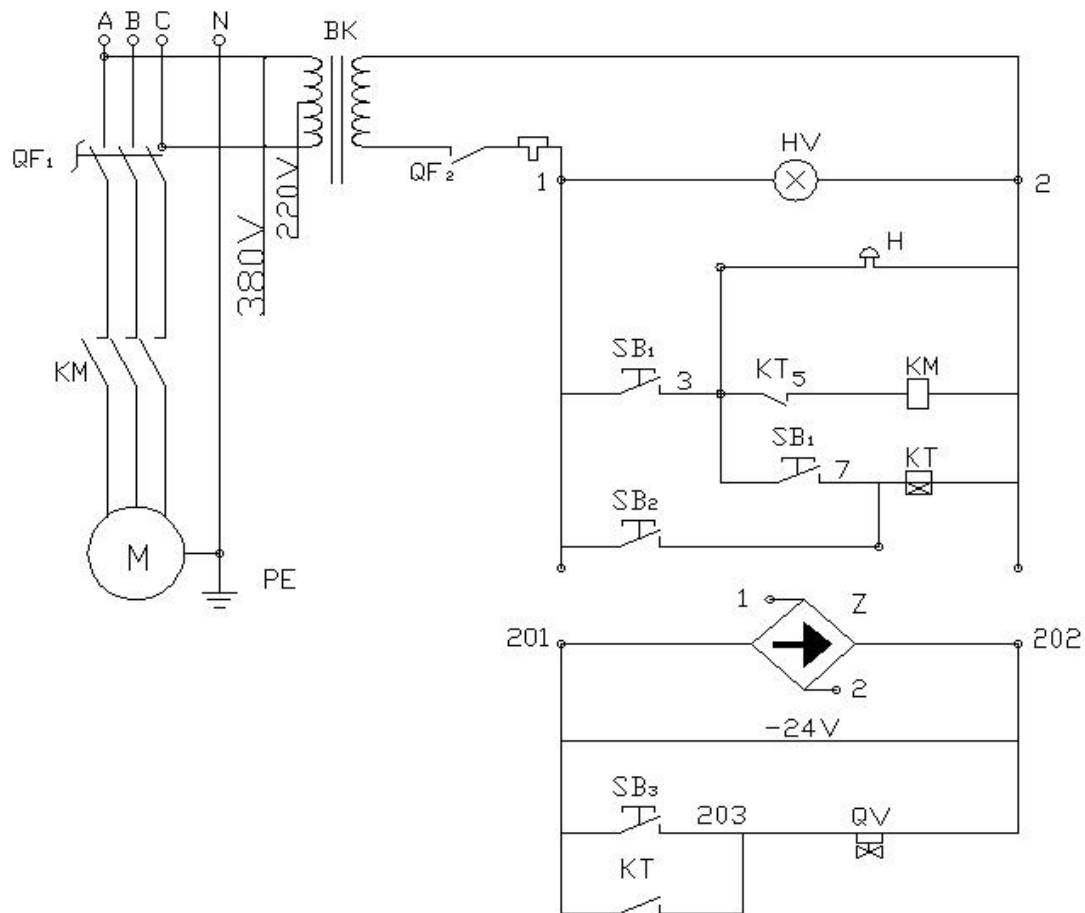

No	Code	Name	Spelifications	Quantity
1	QF1	change over switch	N11	1
2	QF2	miniature breaker	D847-631PC3A	1
3	H	buzzer	ND16 AC24V	1
4	SB1,SB2,SB3	button	BA-21	3
5	KM	AC-contactor	CT*2 P10,AC24V	1
6	SQP	travel switch	BLXW-6/11ZL(T311)	1
7	KT	timer	JSYZ6-5S,AC24V	1
8	QV	pneumatic eletromagnetic valve	3V210-8,AC24V	1
9	Z	rectifier block	KBDC35-10	1
10	M	motor	YX90-3.0KW-2P}380V YX90-3.0KW-2P}220V	1

10、HYDRAULIC SYSTEM

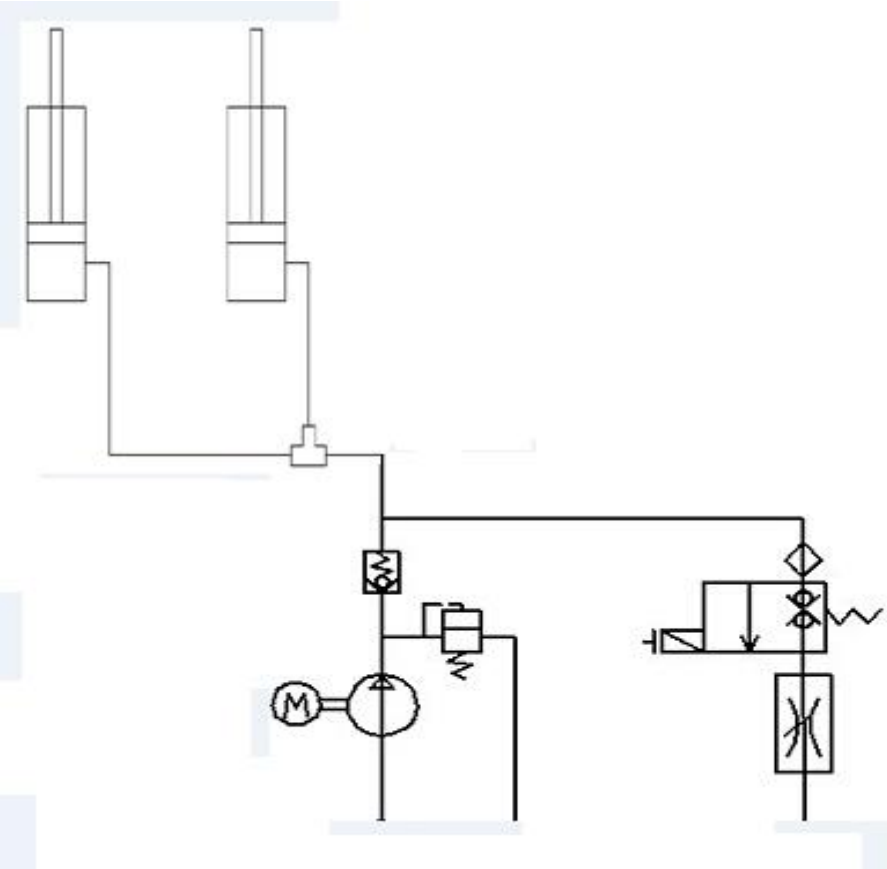

11、 Structure principle diagram

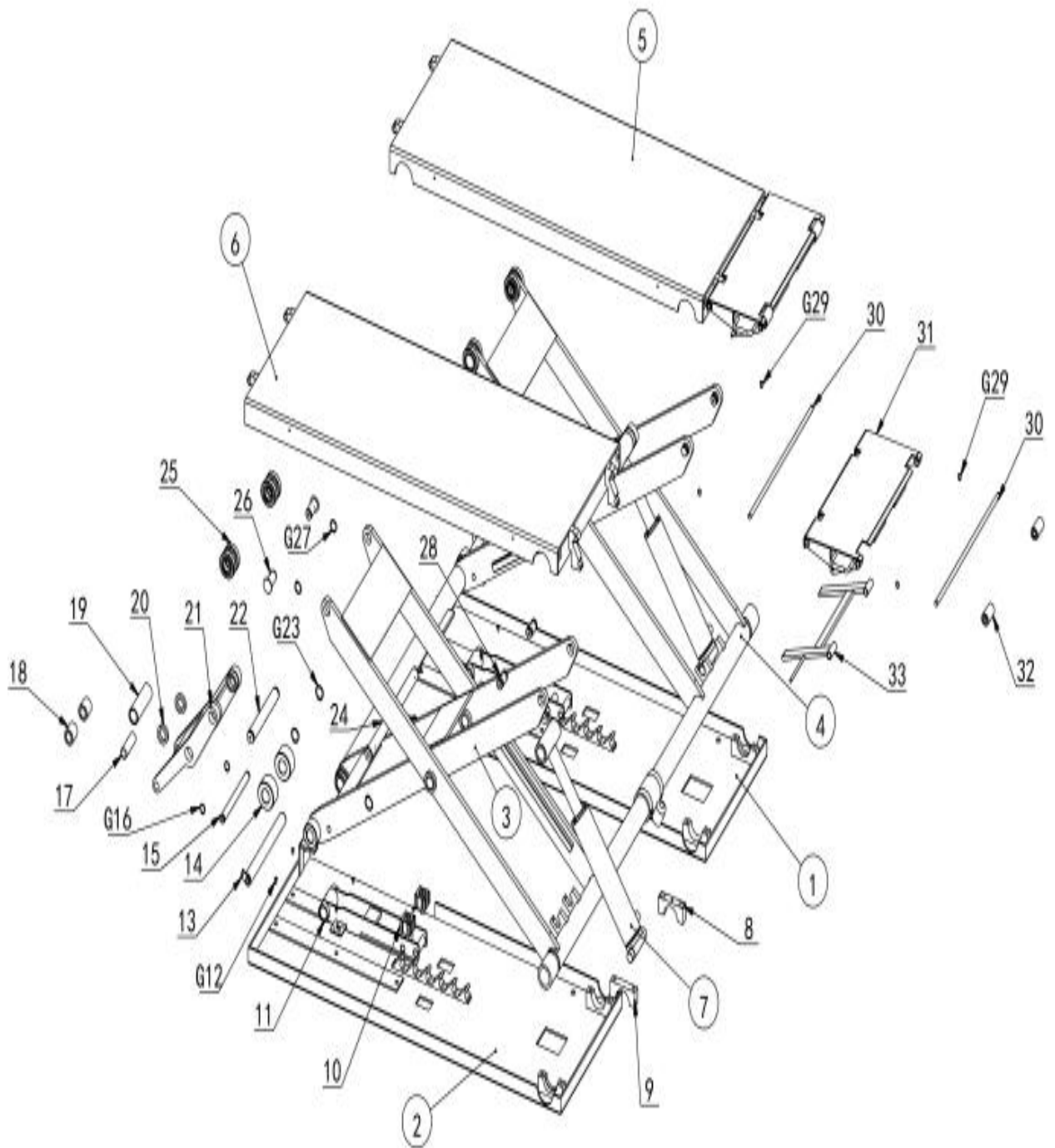

1	Left baseplate	1	
2	Right base plate	1	
3	inner arm	1	
4	Outter arm	1	
5	Left upper cover plate	1	
6	Right upper cover plate	1	
7	Cylinder	2	
8	Supporting arm upper fixing seat	1	
9	Supporting arm lower fixing seat	1	
10	SDA20X15air cylinder	4	
11	Lock gear	2	
12	Cross head screws	12	M6X10
13	The pulley shaft welding	2	
14	Inner supporting arm roller	4	
15	Starting arm walking axis	2	
16	Spring	4	Φ20
17	Wheel space	2	
18	Starting wheel	4	
19	Inner supporting arm bushing	2	
20	bearing retainer	4	
21	Start arm	2	
22	Cylinder upper shaft	2	
23	Spring	8	Φ30
24	The arm shaft	2	
25	trolley wheel	8	
26	trolley wheel shaft	4	
27	Spring	4	Φ25
28	Upper cover fixing shaft	4	
29	Spring	8	Φ12
30	Bridge axis	4	
31	Ramp	2	
32	trolley wheel	4	
33	Bridge bracket	2	